

GENERAL

The Caproco Retriever and Service Valve are designed to install and retrieve internal corrosion monitoring equipment within an operating system while under full working pressure (up to 3,600 psi / 24.8 MPa). A 6,000 psi (41.4 MPa) model is also available. The key components to the Caproco Retrieval System, the Retriever and Service Valve are versatile tools with a proven history of reliable and safe performance in field applications.

Both the retriever and service valve have been specifically designed for the purpose of retrieval under pressure through a 2" access fitting body, and incorporate many features to ensure that the equipment may be used safely, swiftly and without difficulty.

RETRIEVER

The retriever's main components are manufactured from stainless steel, and receive a chroming treatment for resistance to mechanical / corrosion damage and to ensure many years of reliable service. Seven standard sizes of retrievers are offered to cover most service requirements, while custom-ordered sizes are available upon request.

The retriever works on a pressure-balanced principle. This safety feature ensures that in the event of sudden pressure release from the system, the retriever will not telescope.

The Caproco retriever is designed to operate strictly under mechanical principles, and the number of turns to completely seat or retract a component is a known constant. This allows the operator to have complete control over installation or removal, and is a distinct advantage over other models of retriever / access systems.

SERVICE VALVE

The service valve's compact length of 9" (23 cm) makes it easy to handle and store. One of its safety features is its two bleed valve design. One valve bleeds to atmosphere and supplements the bleed valve on the retriever, ensuring that the pressure within the assembly may be released. The second bleed valve bypasses the service valve's ball, which allows pressure in the retriever assembly to build up smoothly, preventing the assembly from being unnecessarily shocked. This also allows the ball of the valve to be opened easily, since the valve seats are no longer under load.

The service valve provides a temporary seal at the



access point while the monitoring device is removed for inspection, maintenance or service. A key advantage to the Caproco service valve's design is that it can swivel even once tightened onto the access fitting, so that the operator may orientate it in a position that gives clear access to the bleed-port and drain valves and handle, taking into account any encumbrances that may be present in the working space.

An optional diverter hose is available so that the fluid within the assembly may be contained in a tank (as a means of sampling) or released elsewhere. The diverter hose may be connected to either the retriever or the service valve.

Depending on the length of monitoring equipment being installed, one retriever and service valve may be used to service many access fitting locations.

SPECIFICATIONS

Caproco retrievers are manufactured from stainless steel, with chromed inner and outer barrels. The service valve is manufactured from carbon steel with a stainless steel ball. Retrievers and service valves are pressure tested after assembly to ensure proper field performance.

Table 1

RETRIEVER STROKE		14"	18"	26"	34"	42"	50"	60"
Retriever	Collapsed	22.50	26.50	34.50	42.50	50.50	58.50	68.50
	Extended	36.50	44.50	60.50	76.50	92.50	108.50	128.50
Working	Clearance	48.00	56.00	72.00	88.00	104.00	120.00	140.00
Maximum Equipment Length								
Strip Coupon Holder		3.50	7.50	15.50	23.50	31.50	39.50	49.50
Flush Coupon Holder		5.00	9.00	17.00	25.00	33.00	41.00	51.00
Probe		4.625	8.625	16.625	24.625	32.625	40.625	50.625
Injection Tube/Quill		2.00	6.00	14.00	22.00	30.00	38.00	48.00

Note: Ensure retrieval location has clearance for the extended assembly

Table 2

RETRIEVER KIT (3,600 PSI / 500°F)			
Stroke	Part Number	Stroke	Part Number
14 "	46080	42 "	11430
18 "	46180	50 "	11440
26 "	11390	60 "	11370
34 "	11420		
Service Valve (3,600 psi / 500°F)			11632

ORDERING INFORMATION

- 1) Determine the maximum length of holder/probe that is to be used
- 2) Choose the retriever of stroke length able to accommodate the maximum equipment length from Table 1 (See figure 2, length B for illustration. Select part number for retriever from Table 2.
- 3) Include any spare parts or optional equipment from Table 3.

Note: The service valve is compatible with any size of retriever.

The retriever kit includes a heavy-duty travel case, operating manual, brass hammer, clamp, hand tools, grease and retriever head bar. The service valve kit includes a brass hammer, operating manual, valve handle extension bar, hand tools, grease and heavy-duty travel case.

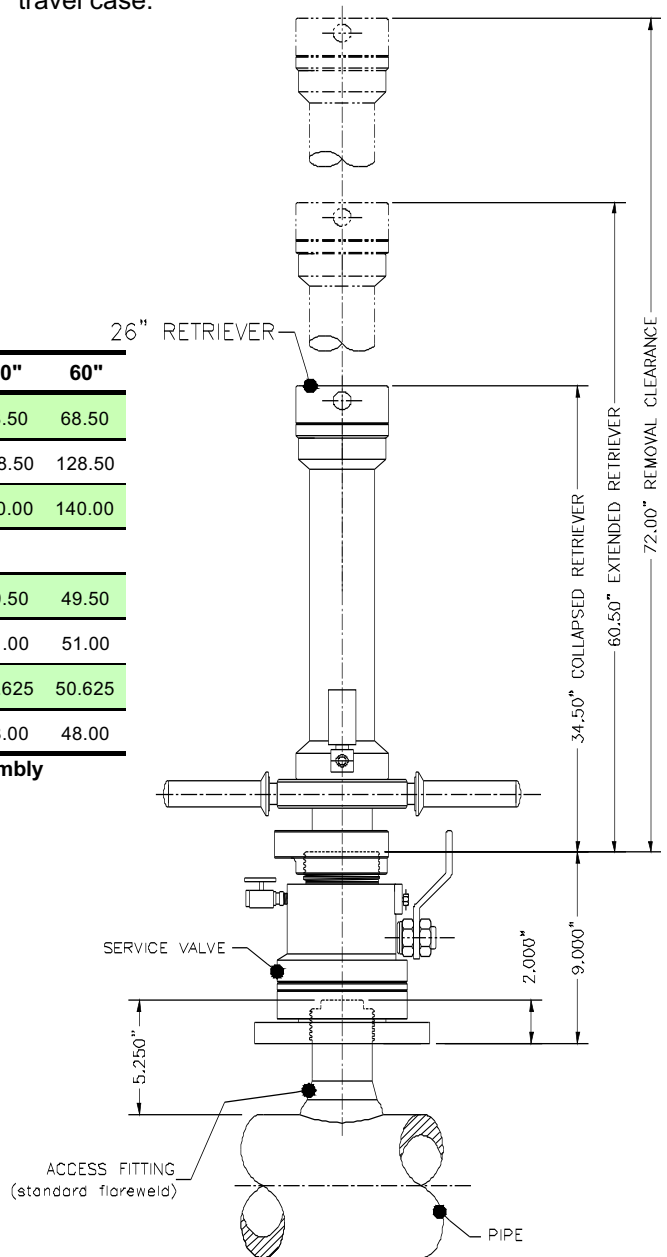

RETRIEVER AND SERVICE VALVE ~ 3,600 PSI

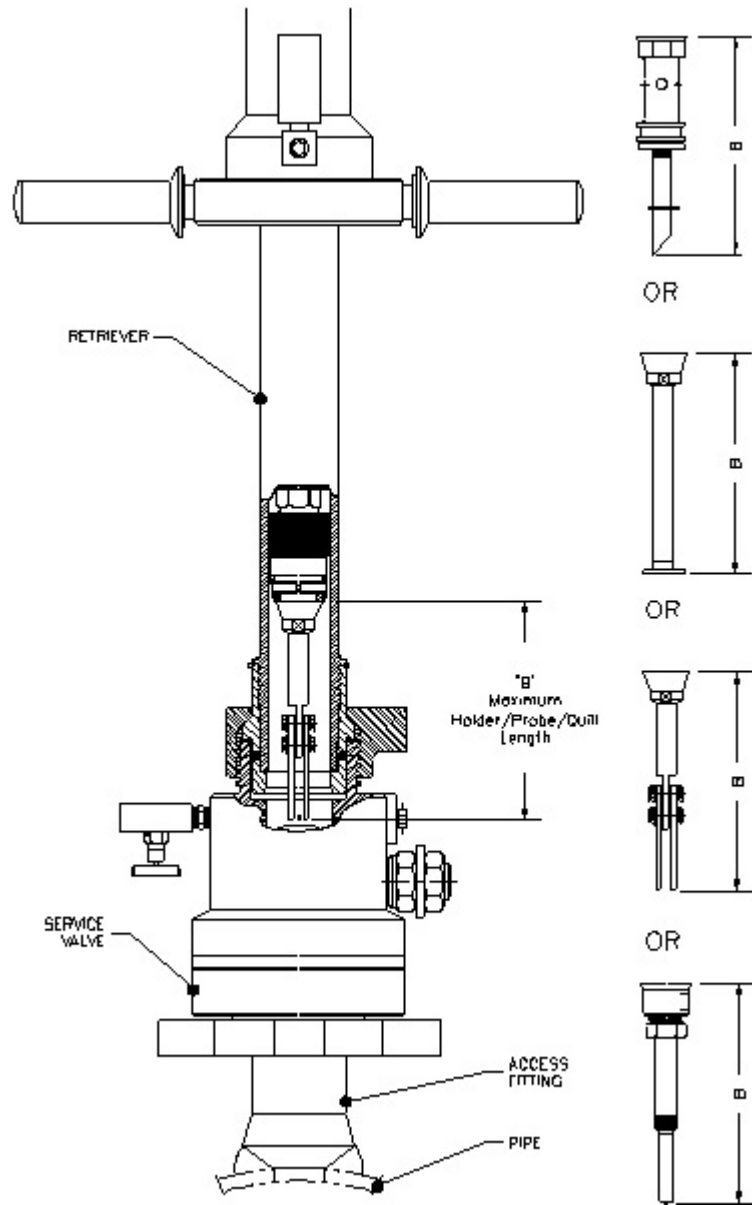

Figure 2

TABLE 3

SPARE PARTS	PART NUMBER
Retriever Repair Kit	11280
Retriever Seal Kit	11281
Service Valve Repair Kit	11633
Service Valve Seal Kit	11634
Retriever Head Bar	11456
Retriever Clamp	11418
Brass Hammer	11450

OPTIONAL	
Seat Reamer	11740
Thread Chaser	11533
Diverter Hose Assembly (10' / 3m)	11612
Back Pressure Pump (5 Gallon/ 19 L)	11673
Surge Tube Assembly	11613